

JEK Technical Services, LLC
3 Delta Drive
Nashua, New Hampshire 03060
Phone: (603) 791-4233

AccessExtender™-400 using ScanPathBuffer™-8 technology

Users Manual

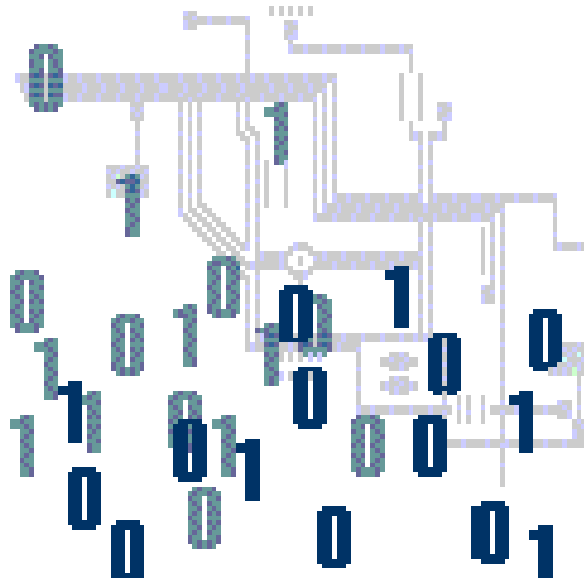

Date: September 29, 2008
Revision: 1.0

JEK Technical Services, LLC reserves the right to make changes to the circuit or specification at any time without notice. Information provided by JEK-Tech™ is believed to be accurate and reliable. JEK-Tech™ assumes no responsibility for its use or for infringement of patents or other third party rights, which may result from its use.

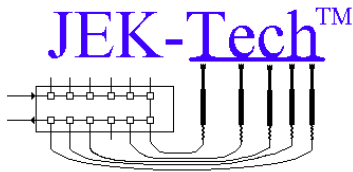

JEK Technical Services, LLC
3 Delta Drive
Nashua, New Hampshire 03060
Phone: (603) 791-4233

Table of Contents

1.	ScanPathBuffer™-8 (SPB-8) Technology.....	3
1.1.	SPB-8 within an AccessExtender™-400.....	4
2.	Recommended Applications	6
2.1.	Backplane or Multiple UUTs	6
2.2.	Multiple Scan Paths on one Unit-Under-Test.....	6
3.	Power Requirements	7
4.	Scan In and Scan Out Connectors.....	7
5.	Voltage Settings	8
6.	Signal Pinout	8
7.	ScanPathBuffer™ TCK rates.....	12
7.1.	Switching Characteristics (SPB-8).....	12
8.	Contact Information	12

JEK Technical Services, LLC reserves the right to make changes to the circuit or specification at any time without notice. Information provided by JEK-Tech™ is believed to be accurate and reliable. JEK-Tech™ assumes no responsibility for its use or for infringement of patents or other third party rights, which may result from its use.

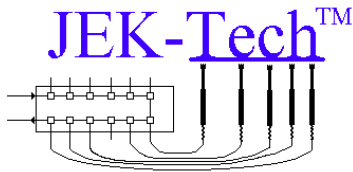

JEK Technical Services, LLC
 3 Delta Drive
 Nashua, New Hampshire 03060
 Phone: (603) 791-4233

1. ScanPathBuffer™-8 (SPB-8) Technology

This document discusses the ScanPathBuffer™ technology within an AccessExtender™-400 (AE400) product. The ScanPathBuffer™ technology requires **NO** special TAP Protocol or unique software code for normal operation. By connecting multiple IEEE1149.1 Boundary Scan Test Access Port (TAP) paths into one scan chain, test coverage is easily increased by allowing across TAP boundary scan testing. Multiple Unit-Under-Test (UUT) products may be ‘rippled’ through (tested) using the same test program.

The ScanPathBuffer™-8 technology (SPB-8) is intended for use when multiple IEEE1149.1 Test Access Ports (TAPs) need to be connected together on your hardware product and a higher TCK rate is needed than available from the SPB-16. This technology allows up to eight (8) TAPs to be dynamically selected in any combination.

ScanPathBuffer™ Technology Overview

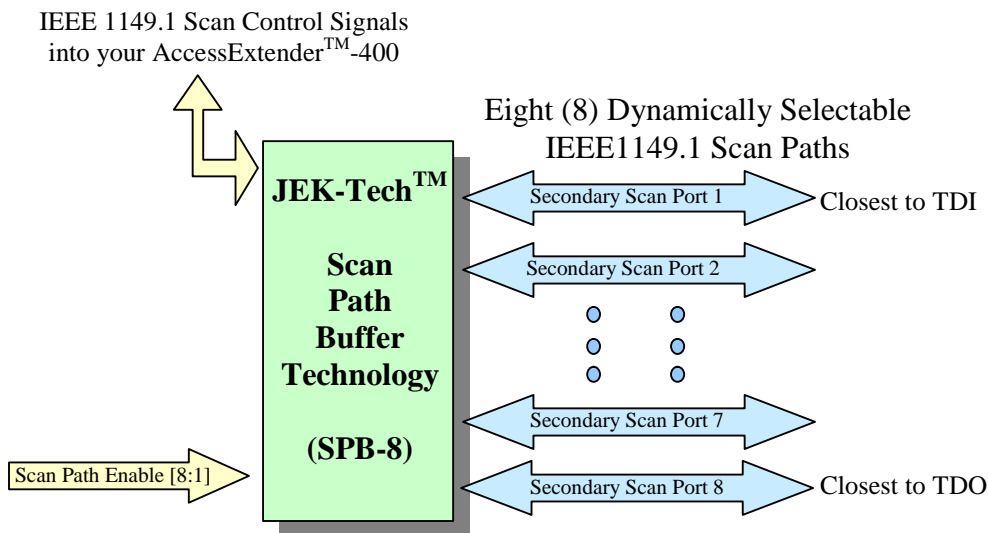

Replacing 100 (of the 400 available) Boundary Scan I/O within the AccessExtender™-400 with the ScanPathBuffer™-8 technology, allows the user to concatenate up to 8 different Scan Chains of the same voltage level and still have 300 Boundary Scan I/O available. Dynamic Scan Path selection of enabled Scan Chain(s) is performed by driving one enable pin for each path. Enable pins may be statically set via jumpers, or dynamically set with external discrete I/O from your tester.

JEK Technical Services, LLC reserves the right to make changes to the circuit or specification at any time without notice. Information provided by JEK-Tech™ is believed to be accurate and reliable. JEK-Tech™ assumes no responsibility for its use or for infringement of patents or other third party rights, which may result from its use.

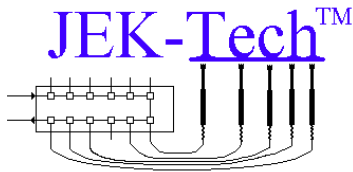

JEK Technical Services, LLC
 3 Delta Drive
 Nashua, New Hampshire 03060
 Phone: (603) 791-4233

Multiple ScanPathBuffer™-8's may be employed within the same AccessExtender™-400, to provide up to 32¹ (4x8) selectable Scan Paths at four (4) different voltage levels².

1.1. SPB-8 within an AccessExtender™-400

The AccessExtender™-400 contains four primary Boundary Scan devices U100, U200, U300 and U400. Normally, the user will add these device BSDLs, along with the AccessExtender™-400 netlist, to his/her UUT design netlist and merge the I/O connectors to the UUT. With the SPB-8 inside the AccessExtender™-400, the user merely has to remove (or not include) the BSDL for the AccessExtender™-400 device (U100, U200, U300 or U400) that is now replaced with the SPB-8 and add in his/her UUT BSDL devices in the order wired to the SPB-8.

In our example drawing below, the AccessExtender™-400 has U100 replaced with an SPB-8. TAP Port 1 is closest to U100's TDI (and AE400's TDI on J18), followed sequentially by all the other TAP Ports, with TAP Port 8 is closest to U100's TDO (this TDO feeds the AE400s U200 device).

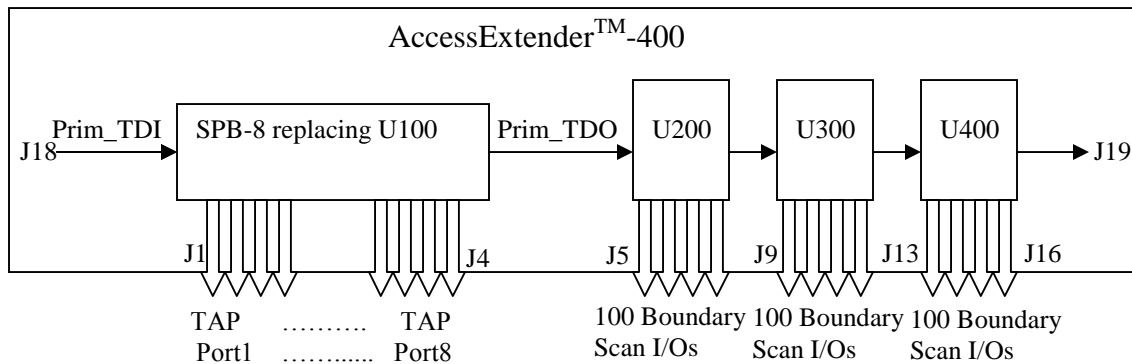

The engineer would build his/her Scan Chain design, including the BSDLs in the following order;

- TDI (J18)**
- SPB-8 TAP Port1 TDI->TDO UUT BSDLs
- SPB-8 TAP Port2 TDI->TDO UUT BSDLs
- SPB-8 TAP Port(n) TDI->TDO UUT BSDLs
- AE400 U200 BSDL
- AE400 U300 BSDL

¹ Maximum TCK frequency may require de-rating.

² One voltage level per 100 I/O.

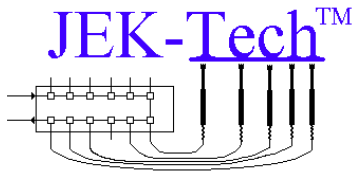

JEK Technical Services, LLC

3 Delta Drive

Nashua, New Hampshire 03060

Phone: (603) 791-4233

AE400 U400 BSDL

Any other TDI->TDO UUT BSDLs (driven off of J19)

TDO

To enable any of the SPB-8 TAP Ports, the user should hold that specific ports' enable pin to ground. Refer to the Signal Pinout specification below for detail pins.

For proper I/O voltage settings of the SPB-8 TAP signals, please refer to the AccessExtender™-400 Users Manual document.

JEK Technical Services, LLC reserves the right to make changes to the circuit or specification at any time without notice. Information provided by JEK-Tech™ is believed to be accurate and reliable. JEK-Tech™ assumes no responsibility for its use or for infringement of patents or other third party rights, which may result from its use.

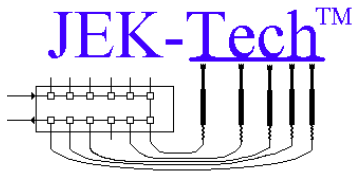

JEK Technical Services, LLC
3 Delta Drive
Nashua, New Hampshire 03060
Phone: (603) 791-4233

2. Recommended Applications

Using the ScanPathBuffer™-8 technology within an AccessExtender™-400 allows the user to connect up to eight (8) different IEEE1149.1 TAP Ports.

2.1. Backplane or Multiple UUTs

The AccessExtender™-400 with ScanPathBuffer™ technology can be used to test multiple Units Under Test (UUTs) on the bench or in a backplane configuration.

AccessExtender™-400 with one ScanPathBuffer™-8

IEEE 1149.1 Scan Control signals
into your AccessExtender™-400

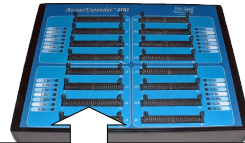

(8) Selectable IEEE1149.1 Scan Paths
+ 300 available I/O

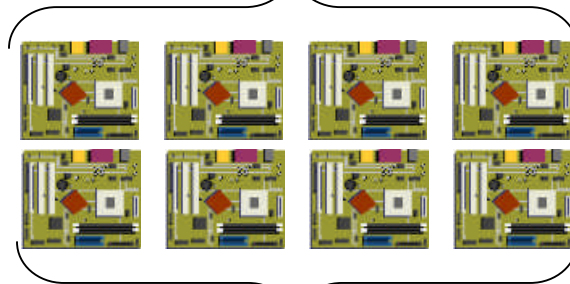

One AccessExtender™-400 I/O
Voltage Level

2.2. Multiple Scan Paths on one Unit-Under-Test

The AccessExtender™-400 with ScanPathBuffer™ technology can be used to statically or dynamically connect multiple scan paths on one UUT.

JEK Technical Services, LLC reserves the right to make changes to the circuit or specification at any time without notice. Information provided by JEK-Tech™ is believed to be accurate and reliable. JEK-Tech™ assumes no responsibility for its use or for infringement of patents or other third party rights, which may result from its use.

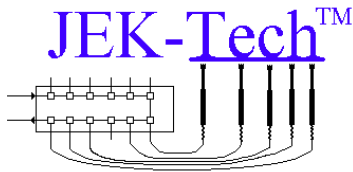

JEK Technical Services, LLC
3 Delta Drive
Nashua, New Hampshire 03060
Phone: (603) 791-4233

AccessExtender™-400 with ScanPathBuffer™ technology

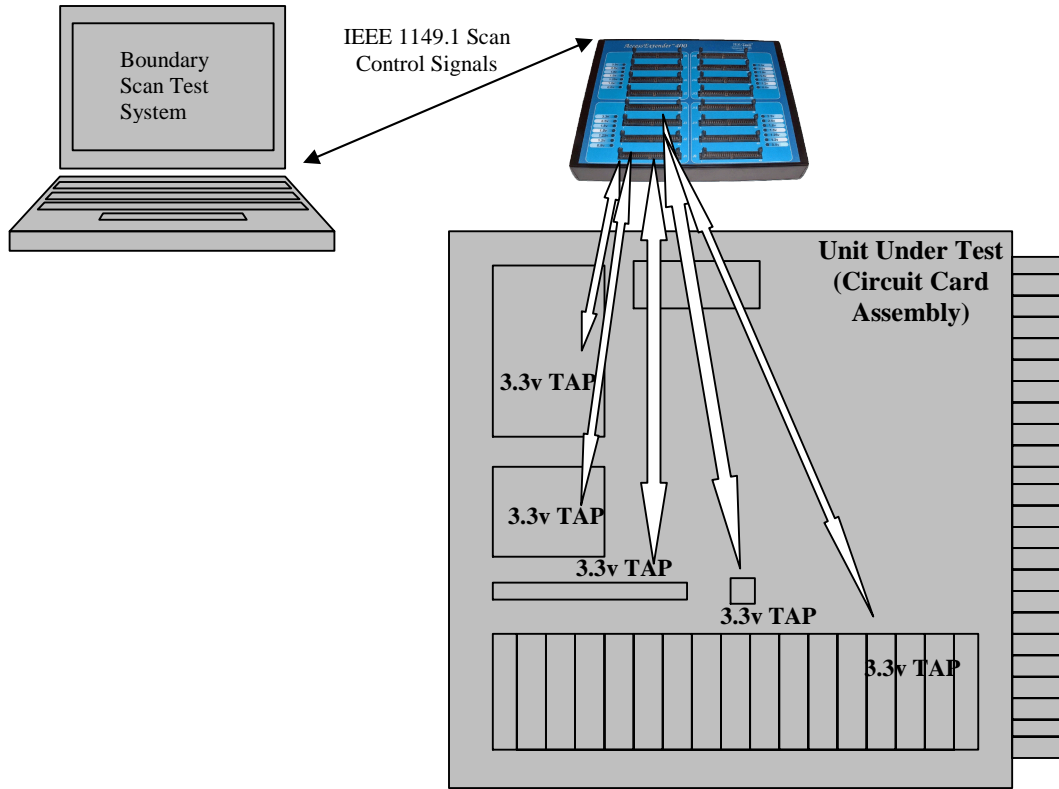

3. Power Requirements

Refer to the AccessExtender™-400 Users Manual document. This technology requires no additional power beyond that already used by the AccessExtender™-400.

4. Scan In and Scan Out Connectors

Refer to the AccessExtender™-400 Users Manual document. This technology requires no additional connections beyond that already defined by the AccessExtender™-400 Users Manual. The standard Scan In (J18) and Scan Out (J19) connectors remain the primary IEEE1149.1 input/output connections for the AccessExtender™-400.

JEK Technical Services, LLC reserves the right to make changes to the circuit or specification at any time without notice. Information provided by JEK-Tech™ is believed to be accurate and reliable. JEK-Tech™ assumes no responsibility for its use or for infringement of patents or other third party rights, which may result from its use.

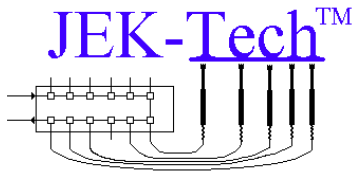

JEK Technical Services, LLC
3 Delta Drive
Nashua, New Hampshire 03060
Phone: (603) 791-4233

5. Voltage Settings

Refer to the AccessExtender™-400 Users Manual document. This technology requires that the user set the I/O voltages appropriately for the SPB-8 UUT TAP connections to match the UUT requirements.

6. Signal Pinout

AccessExtender™-400 with ScanPathBuffer™ technology has a unique IEEE1149.1 TAP pin-out configuration. Refer to the AccessExtender™-400 Users Manual document and the below Signal Pinout definitions.

NOTE: On connectors J1 thru J16, the odd number pins (1 through 49) are grounds. It is the users' responsibility to ensure that proper signal cable grounding is employed. JEK-Tech™ strongly recommends employing a ground/signal/ground/signal/ground... configuration, for the best signal crosstalk immunity. Our connector design creates this configuration when ribbon cables are used.

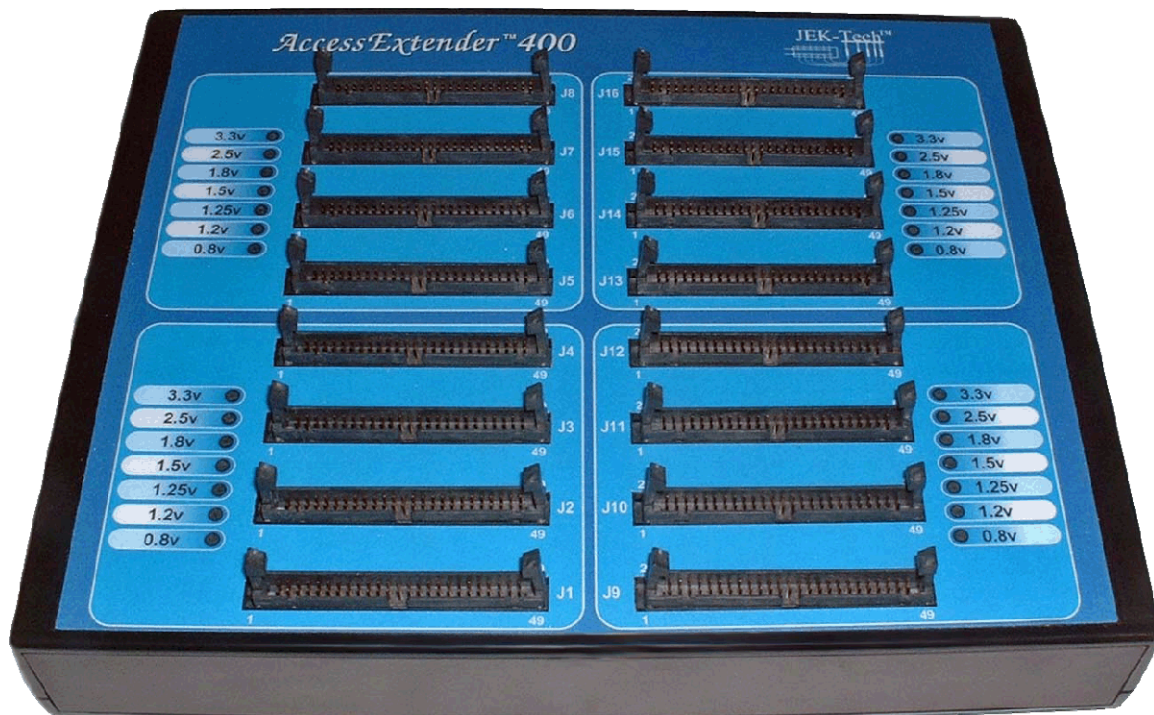

The SPB-8 can replace any (of 4) bank(s) of 100 Boundary Scan I/Os. The user MUST be aware of which I/O device (U100, U200, U300 and U400) has been replaced with an SPB-8. JEK-Tech™ labels the bottom each AccessExtender™-400 appropriately for ongoing reference.

JEK Technical Services, LLC reserves the right to make changes to the circuit or specification at any time without notice. Information provided by JEK-Tech™ is believed to be accurate and reliable. JEK-Tech™ assumes no responsibility for its use or for infringement of patents or other third party rights, which may result from its use.

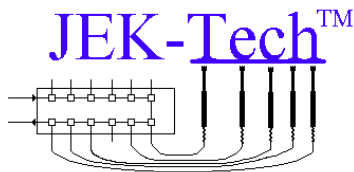

JEK Technical Services, LLC

3 Delta Drive

Nashua, New Hampshire 03060

Phone: (603) 791-4233

ScanPathBuffer™-8 Signal Pinout per AccessExtender™-400 Reference designator

<u>U100</u>	<u>U200</u>	<u>U300</u>	<u>U400</u>	New Pin Function=>	<u>Signal Name</u>	<u>Signal Function/Description</u>
J1-2	J5-2	J9-2	J13-2	Output	Port1_TCK	Output from AccessExtender™-400 to UUT
J1-4	J5-4	J9-4	J13-4	Output	Port1_TRST	Output from AccessExtender™-400 to UUT
J1-6	J5-6	J9-6	J13-6	Output	Port1_TDI	Output from AccessExtender™-400 to UUT
J1-8	J5-8	J9-8	J13-8	Output	Port1_TMS	Output from AccessExtender™-400 to UUT
J1-10	J5-10	J9-10	J13-10	Input	Port1_TDO	Input from UUT into AccessExtender™-400
J1-12	J5-12	J9-12	J13-12	Output	Port2_TCK	Output from AccessExtender™-400 to UUT
J1-14	J5-14	J9-14	J13-14	Output	Port2_TRST	Output from AccessExtender™-400 to UUT
J1-16	J5-16	J9-16	J13-16	Output	Port2_TDI	Output from AccessExtender™-400 to UUT
J1-18	J5-18	J9-18	J13-18	Output	Port2_TMS	Output from AccessExtender™-400 to UUT
J1-20	J5-20	J9-20	J13-20	Input	Port2_TDO	Input from UUT into AccessExtender™-400
J1-22	J5-22	J9-22	J13-22	Output	Port3_TCK	Output from AccessExtender™-400 to UUT
J1-24	J5-24	J9-24	J13-24	Output	Port3_TRST	Output from AccessExtender™-400 to UUT
J1-26	J5-26	J9-26	J13-26	Output	Port3_TDI	Output from AccessExtender™-400 to UUT
J1-28	J5-28	J9-28	J13-28	Output	Port3_TMS	Output from AccessExtender™-400 to UUT
J1-30	J5-30	J9-30	J13-30	Input	Port3_TDO	Input from UUT into AccessExtender™-400
J1-32	J5-32	J9-32	J13-32	Output	Port4_TCK	Output from AccessExtender™-400 to UUT
J1-34	J5-34	J9-34	J13-34	Output	Port4_TRST	Output from AccessExtender™-400 to UUT
J1-36	J5-36	J9-36	J13-36	Output	Port4_TDI	Output from AccessExtender™-400 to UUT
J1-38	J5-38	J9-38	J13-38	Output	Port4_TMS	Output from AccessExtender™-400 to UUT
J1-40	J5-40	J9-40	J13-40	Input	Port4_TDO	Input from UUT into AccessExtender™-400
J1-42	J5-42	J9-42	J13-42	DNU	DNU	Do Not Use. A low on this pin disables the SPB-8 output. For Factory use only.
J1-44	J5-44	J9-44	J13-44	Control	Enable_Port1	Low enables port. Floats high(disabled).
J1-46	J5-46	J9-46	J13-46	Control	Enable_Port2	Low enables port. Floats high(disabled).
J1-48	J5-48	J9-48	J13-48	Control	Enable_Port3	Low enables port. Floats high(disabled).
J1-50	J5-50	J9-50	J13-50	Control	Enable_Port4	Low enables port. Floats high(disabled).
J2-2	J6-2	J10-2	J14-2	Output	Port5_TCK	Output from AccessExtender™-400 to UUT
J2-4	J6-4	J10-4	J14-4	Output	Port5_TRST	Output from AccessExtender™-400 to UUT
J2-6	J6-6	J10-6	J14-6	Output	Port5_TDI	Output from AccessExtender™-400 to UUT
J2-8	J6-8	J10-8	J14-8	Output	Port5_TMS	Output from AccessExtender™-400 to UUT
J2-10	J6-10	J10-10	J14-10	Input	Port5_TDO	Input from UUT into AccessExtender™-400
J2-12	J6-12	J10-12	J14-12	Output	Port6_TCK	Output from AccessExtender™-400 to UUT
J2-14	J6-14	J10-14	J14-14	Output	Port6_TRST	Output from AccessExtender™-400 to UUT

JEK Technical Services, LLC reserves the right to make changes to the circuit or specification at any time without notice. Information provided by JEK-Tech™ is believed to be accurate and reliable. JEK-Tech™ assumes no responsibility for its use or for infringement of patents or other third party rights, which may result from its use.

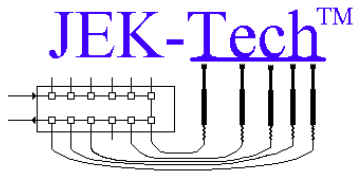

JEK Technical Services, LLC

3 Delta Drive

Nashua, New Hampshire 03060

Phone: (603) 791-4233

J2-16	J6-16	J10-16	J14-16	Output	Port6_TDI	Output from AccessExtender™-400 to UUT
J2-18	J6-18	J10-18	J14-18	Output	Port6_TMS	Output from AccessExtender™-400 to UUT
J2-20	J6-20	J10-20	J14-20	Input	Port6_TDO	Input from UUT into AccessExtender™-400
J2-22	J6-22	J10-22	J14-22	Output	Port7_TCK	Output from AccessExtender™-400 to UUT
J2-24	J6-24	J10-24	J14-24	Output	Port7_TRST	Output from AccessExtender™-400 to UUT
J2-26	J6-26	J10-26	J14-26	Output	Port7_TDI	Output from AccessExtender™-400 to UUT
J2-28	J6-28	J10-28	J14-28	Output	Port7_TMS	Output from AccessExtender™-400 to UUT
J2-30	J6-30	J10-30	J14-30	Input	Port7_TDO	Input from UUT into AccessExtender™-400
J2-32	J6-32	J10-32	J14-32	Output	Port8_TCK	Output from AccessExtender™-400 to UUT
J2-34	J6-34	J10-34	J14-34	Output	Port8_TRST	Output from AccessExtender™-400 to UUT
J2-36	J6-36	J10-36	J14-36	Output	Port8_TDI	Output from AccessExtender™-400 to UUT
J2-38	J6-38	J10-38	J14-38	Output	Port8_TMS	Output from AccessExtender™-400 to UUT
J2-40	J6-40	J10-40	J14-40	Input	Port8_TDO	Input from UUT into AccessExtender™-400
J2-42	J6-42	J10-42	J14-42	DNU	DNU	Do Not Use. A low on this pin disables the SPB-8 output. For Factory use only.
J2-44	J6-44	J10-44	J14-44	Control	Enable_Port5	Low enables port. Floats high(disabled).
J2-46	J6-46	J10-46	J14-46	Control	Enable_Port6	Low enables port. Floats high(disabled).
J2-48	J6-48	J10-48	J14-48	Control	Enable_Port7	Low enables port. Floats high(disabled).
J2-50	J6-50	J10-50	J14-50	Control	Enable_Port8	Low enables port. Floats high(disabled).
J3-2	J7-2	J11-2	J15-2	Unused	n/a	
J3-4	J7-4	J11-4	J15-4	Unused	n/a	
J3-6	J7-6	J11-6	J15-6	Unused	n/a	
J3-8	J7-8	J11-8	J15-8	Unused	n/a	
J3-10	J7-10	J11-10	J15-10	Unused	n/a	
J3-12	J7-12	J11-12	J15-12	Unused	n/a	
J3-14	J7-14	J11-14	J15-14	Unused	n/a	
J3-16	J7-16	J11-16	J15-16	Unused	n/a	
J3-18	J7-18	J11-18	J15-18	Unused	n/a	
J3-20	J7-20	J11-20	J15-20	Unused	n/a	
J3-22	J7-22	J11-22	J15-22	Unused	n/a	
J3-24	J7-24	J11-24	J15-24	Unused	n/a	
J3-26	J7-26	J11-26	J15-26	Unused	n/a	
J3-28	J7-28	J11-28	J15-28	Unused	n/a	
J3-30	J7-30	J11-30	J15-30	Unused	n/a	
J3-32	J7-32	J11-32	J15-32	Unused	n/a	
J3-34	J7-34	J11-34	J15-34	Unused	n/a	
J3-36	J7-36	J11-36	J15-36	Unused	n/a	
J3-38	J7-38	J11-38	J15-38	Unused	n/a	

JEK Technical Services, LLC reserves the right to make changes to the circuit or specification at any time without notice. Information provided by JEK-Tech™ is believed to be accurate and reliable. JEK-Tech™ assumes no responsibility for its use or for infringement of patents or other third party rights, which may result from its use.

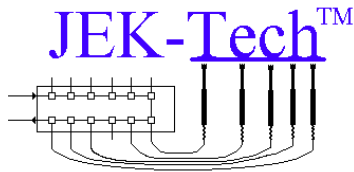

JEK Technical Services, LLC

3 Delta Drive

Nashua, New Hampshire 03060

Phone: (603) 791-4233

J3-40	J7-40	J11-40	J15-40	Unused	n/a
J3-42	J7-42	J11-42	J15-42	Unused	n/a
J3-44	J7-44	J11-44	J15-44	Unused	n/a
J3-46	J7-46	J11-46	J15-46	Unused	n/a
J3-48	J7-48	J11-48	J15-48	Unused	n/a
J3-50	J7-50	J11-50	J15-50	Unused	n/a
J4-2	J8-2	J12-2	J16-2	Unused	n/a
J4-4	J8-4	J12-4	J16-4	Unused	n/a
J4-6	J8-6	J12-6	J16-6	Unused	n/a
J4-8	J8-8	J12-8	J16-8	Unused	n/a
J4-10	J8-10	J12-10	J16-10	Unused	n/a
J4-12	J8-12	J12-12	J16-12	Unused	n/a
J4-14	J8-14	J12-14	J16-14	Unused	n/a
J4-16	J8-16	J12-16	J16-16	Unused	n/a
J4-18	J8-18	J12-18	J16-18	Unused	n/a
J4-20	J8-20	J12-20	J16-20	Unused	n/a
J4-22	J8-22	J12-22	J16-22	Unused	n/a
J4-24	J8-24	J12-24	J16-24	Unused	n/a
J4-26	J8-26	J12-26	J16-26	Unused	n/a
J4-28	J8-28	J12-28	J16-28	Unused	n/a
J4-30	J8-30	J12-30	J16-30	Unused	n/a
J4-32	J8-32	J12-32	J16-32	Unused	n/a
J4-34	J8-34	J12-34	J16-34	Unused	n/a
J4-36	J8-36	J12-36	J16-36	Unused	n/a
J4-38	J8-38	J12-38	J16-38	Unused	n/a
J4-40	J8-40	J12-40	J16-40	Unused	n/a
J4-42	J8-42	J12-42	J16-42	Unused	n/a
J4-44	J8-44	J12-44	J16-44	Unused	n/a
J4-46	J8-46	J12-46	J16-46	Unused	n/a
J4-48	J8-48	J12-48	J16-48	Unused	n/a
J4-50	J8-50	J12-50	J16-50	Unused	n/a

JEK Technical Services, LLC reserves the right to make changes to the circuit or specification at any time without notice. Information provided by JEK-Tech™ is believed to be accurate and reliable. JEK-Tech™ assumes no responsibility for its use or for infringement of patents or other third party rights, which may result from its use.

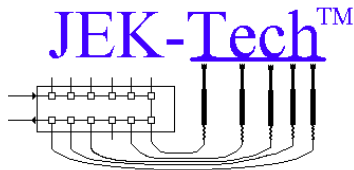

JEK Technical Services, LLC

3 Delta Drive

Nashua, New Hampshire 03060

Phone: (603) 791-4233

7. ScanPathBuffer™ TCK rates

The ScanPathBuffer™ technology contains combinatorial circuit that does not resynchronize TDO data to TCK with PAD cells. For this reason, no additional software coding or unique test vectors are required to use the SPB-8.

When operating combinatorial circuits in a synchronous environment (IEEE1149.1 protocol is synchronous to TCK), the user must be aware that logic propagation and setup times become a concern. For this reason, our design optimized the propagation time through the SPB-8, however, any additional TAP signal propagation time added by your UUT will degrade the maximum TCK speed you can reliably run at. If the user is worried about running at the fastest TCK rates the UUT can operate at, the SPB-8 may not be the solution you need. Consult JEK-Tech for detailed timing and alternative recommendations.

AccessExtender™-400 with one ScanPathBuffer™ Mode	<u>Max. TCK</u> <u>SPB-4</u>	<u>Max. TCK</u> <u>SPB-8</u>	<u>Max. TCK</u> <u>SPB-16</u>
Transparent/PassThru (no TAPs enabled)	22Mhz	22Mhz	20Mhz
One TAP Enabled, TDI-TDO Jumpered	20Mhz	18Mhz	16Mhz
2 TAPs Enabled (AE100s on each³)	10-12Mhz	10-12Mhz	7-8Mhz

7.1. Switching Characteristics (SPB-8)

	From	To	Min.	Nom.	Max.	Units
t _{TCK}	Prim_TCK	Port(n)_TCK ⁴	6.9	8.0	8.7	ns
t _{TMS}	Prim_TMS	Port(n)_TMS	4.3	6.3	7.8	ns
t _{TRST}	Prim_TRST	Port(n)_TRST	4.0	6.2	8.1	ns
t _{prim_tdi_tdo} ⁵	Prim_TDI	Prim_TDO	-	14.6	-	ns
t _{Port1_Prim_TDO}	Port1_TDO	Prim_TDO	-	14.5	-	ns
t _{Port8_Prim_TDO}	Port8_TDO	Prim_TDO	-	7.9	-	ns

8. Contact Information

JEK Technical Services, LLC

3 Delta Drive

Nashua, NH 03060-5823

Phone: 603-791-4233

³ UUT Cables were 2feet and 3.5feet long to the AccessExtender™-100's (AE100). AE100s introduce @10ns return TDO propagation delay. AE400 J1-J4 / U100 location used at an I/O setting of 2.5v for all testing.

⁴ Clock domain offset to each port

⁵ Prim_TDI and Prim_TDO are internal to the AE400, on the SPB-8.

JEK Technical Services, LLC reserves the right to make changes to the circuit or specification at any time without notice. Information provided by JEK-Tech™ is believed to be accurate and reliable. JEK-Tech™ assumes no responsibility for its use or for infringement of patents or other third party rights, which may result from its use.